

BOOTHS—UNIVERSAL (INDOOR-OUTDOOR) KS-16797 INSTALLATION

1. GENERAL

1.01 This section is reissued to:

- (a) Change format of test.
- (b) Add information on directory rack and shelf installation.
- (c) Add information on KS-16797, list 16 seat installation.
- (d) Add information on telephone wiring.
- (e) Add information on electric wiring and grounding.
- (f) Add Fig. 3, 4, 5, 6, 7, 8, 9, and 10.

2. BOOTH INSTALLATION

2.01 Booth location (given on service order) should be:

- Within full view of public
- Readily accessible to customer and workman

- Free of such hazards as broken or uneven pavements and flooring
- Spaced with a minimum clearance of six inches from property lines and buildings
- Placed with as little step up as possible and still maintain proper drainage.

2.02 KS-16797 booth requires anchoring at all outdoor installations. Anchoring at indoor locations is desired; however, this may not be possible in some instances.

2.03 For proper operation of the coin collector, the surface upon which the booth is installed must be smooth and level. At indoor locations, shims may be placed under the floor to correct minor differences. A concrete base can be provided at outdoor locations. Use a level to check that booth is plumb.

2.04 When necessary to provide a concrete base, the KS-16797, List 7 template is used as shown in Fig. 1.

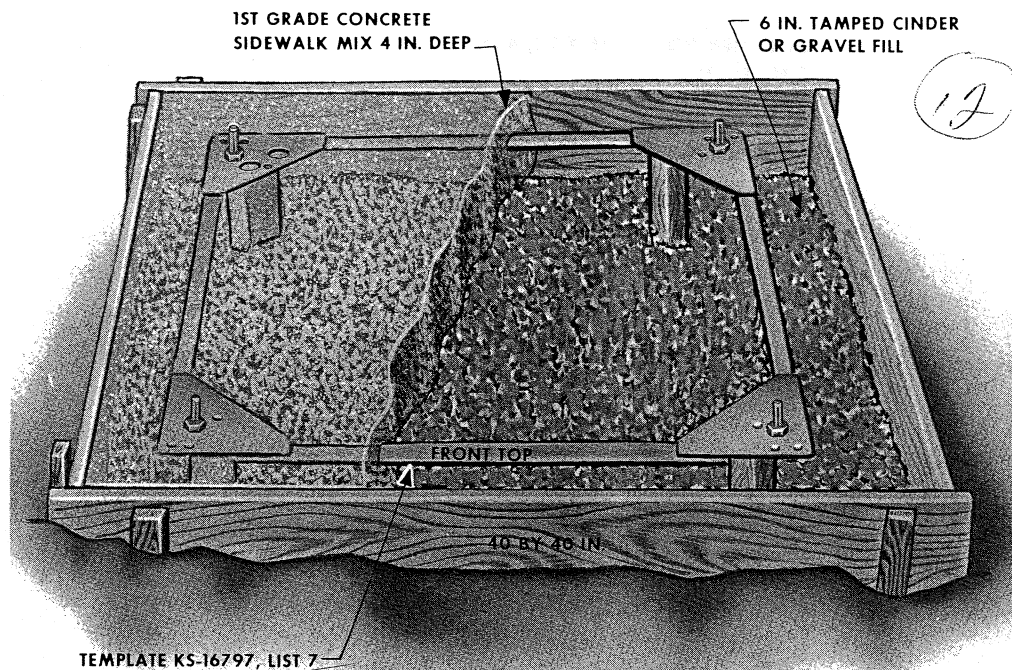

Fig. 1—Base Preparation with KS-16797, List 7 Template

(1) Position the assembled template in the 40-inch square form on wooden blocks so that the top of four mounting inserts will be flush with concrete base (Fig. 2).



Nail holes are provided in the four corners of the template for fastening to the wooden blocks. The wooden blocks may be used to level and support the template at the proper height.

- (2) Provide for holes in the concrete base for underground power and telephone wires at the position of corresponding holes in the template.
- (3) Pour concrete around template to fill the form.
- (4) Do not remove screw plugs from booth mounting inserts until booth is installed. Their sole purpose is to prevent dirt from filling mounting holes.

2.05 For multiple booth installations, fasten adjacent templates together with two No. 10 (.190) -32 x 1/2 RHM steel screws and two No. 10-32 hex nuts.

2.06 Anchor booth as follows:

- (1) With list 7 template, place fasteners in template inserts (see Fig. 2).
- (2) Without template, drill holes in concrete using the floor to mark location of holes. Use 3/8 x 2 inch expansion shields and 3/8 x 2-1/2 inch hexagonal machine bolts to anchor booth. Tighten with box wrench (KS-14962).
- (3) *Wooden platform* (at an outdoor location such as a boardwalk) drill lead hole in platform using floor to mark locations of holes. Use 5/16 x 2-1/2 inch lag screws to anchor booth.
- (4) *Indoor locations*, use an appropriate wood screw or masonry fastener.

Door Requirements

2.07 After anchoring booth, check requirements of booth door as covered in Section 508-230-300.

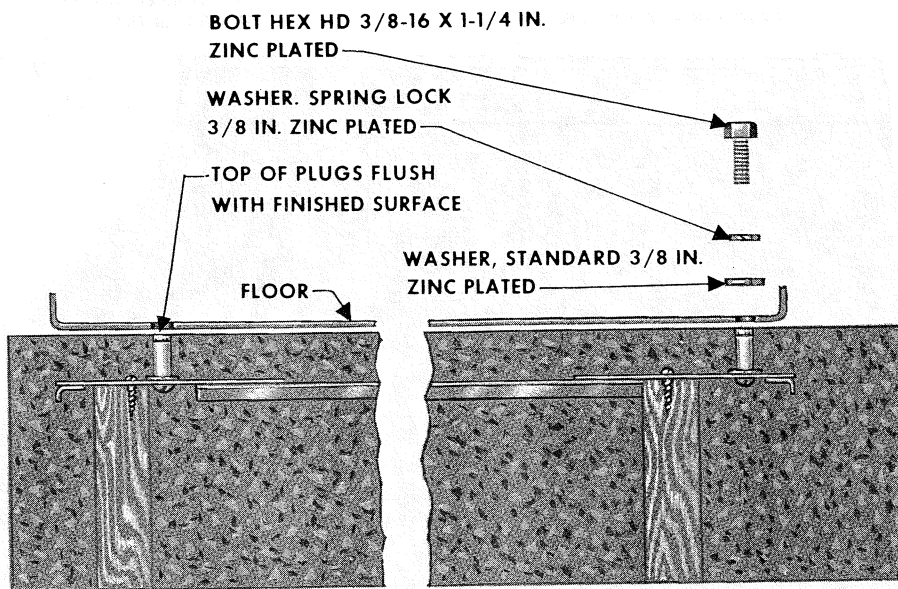

Fig. 2 — Fastening Booth to Template

3. MULTIPLE BOOTH INSTALLATIONS (FIG. 3)

3.01 Arrange the booths before fastening them together so their front, sides, and tops present straight lines.

3.02 A KS-16797, List-11 multiple assembly kit (Fig. 3) for joining booths together is available. This assembly kit consists of:

- 2 Grommets
- 1 Rubber Sealing Strip
- Screws, Nuts, and Washers.

One assembly kit for each adjoining booth is needed.

3.03 When booths have been fastened to the foundation, remove roofs. Then install and wire each booth in the following manner:

- (1) Insert the appropriate bottom panels. Bottom panels are covered in the Identification section.
- (2) Insert the KS-16797, List 8 frames into the empty panel spaces.



The list 8 frame eliminates the use of double panels between booths.

- (3) Insert the KS-16797, List 12 sign blanks, and fasten the booths together with the screws, nuts, and washers at this point. Install the list 8 frames and the sign blanks the same way as the KS-14611 panels.
- (4) Push wires through the grommets, and complete the wiring of all booths.
- (5) Remove backing from the rubber sealing strip. Place the sealing strip along the joint between the two joining booths.
- (6) Remove the knockouts from the joining sides of the booth roofs.
- (7) Put one roof back in place. Insert the grommets in the knockout spaces. Install next roof. Be sure that each grommet seals the knockout spaces. Tighten the roofs.

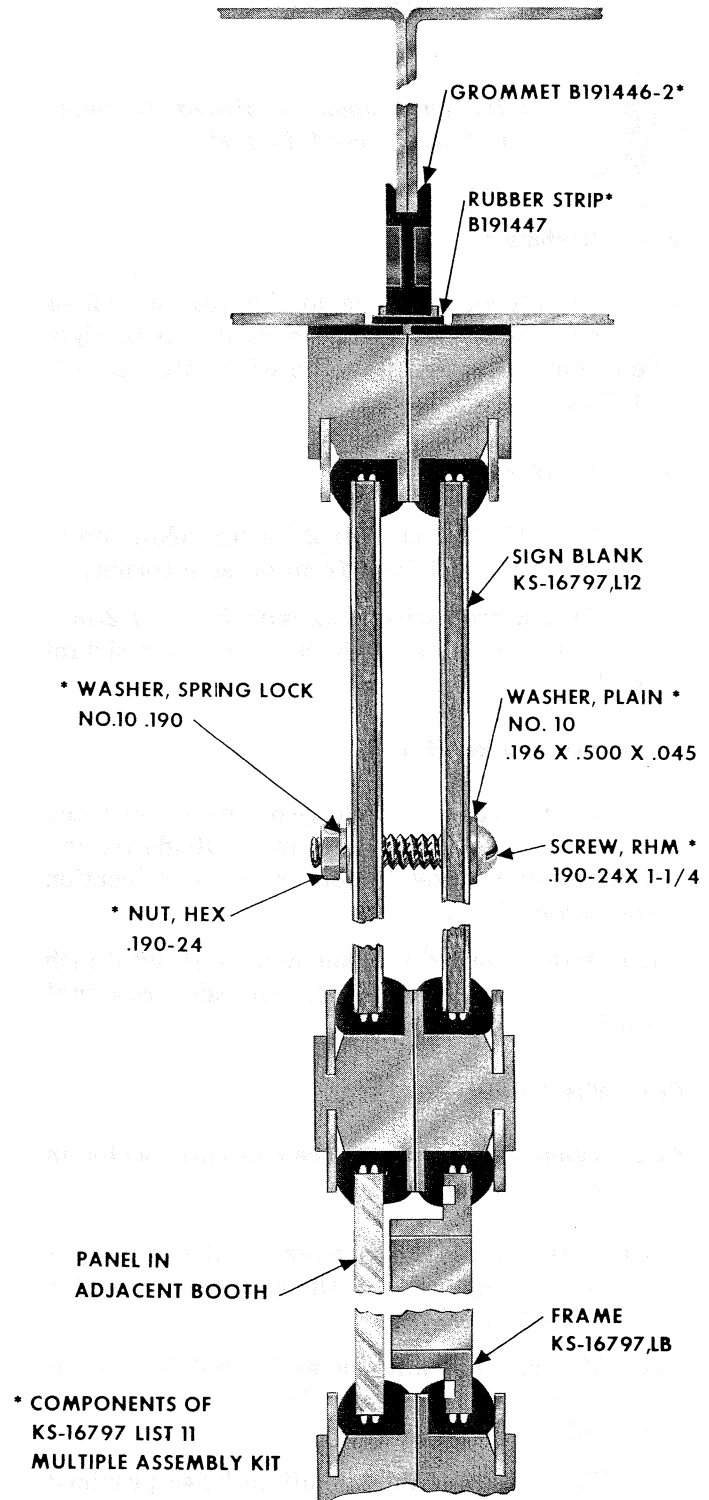

Fig. 3 — Connecting Booths

- (8) On outdoor installations only, seal the top joint between adjoining roofs with caulking compound.

4. TELEPHONE WIRING



Aerial wire spans fastened to booth should not exceed 25 feet.

First Attachment

4.01 At outdoor locations, attach drop wire hook or corner bracket on the right rear or right side column directly below the wire entrance hole as follows:

A. Drop Wire Hook (Fig. 4)

- (1) Drill 11/32-inch hole 2 inches below top of column and 1 inch from outside corner.
- (2) Attach drop wire hook with 5/16 by 2-inch stove bolt and 3/8-inch corrosion resistant washers.

B. Corner Bracket (Fig. 5)

- (1) Drill 11/32-inch hole two inches below top of column and 1 inch from outside corner. Use corner bracket to determine exact location for second hole.
- (2) Attach corner bracket with 5/16 by 2-inch stove bolt and 3/8-inch corrosion resistant washers.

Drop Wire Connection

4.02 Telephone wire entrance holes are located in several locations:

- (a) Through entrance holes located at right rear or right side of the roof assembly (for overhead entrance).
- (b) Through entrance holes located in the list 23 or list 123 solid bottom panels (for ground level entrance).
- (c) Through metallic conduit to holes provided in the left rear corner of the booth floor (for underground entrance).

4.03 Insert drop wire through entrance hole and terminate on 123A1A station protector or 42A connecting block (whichever is required).

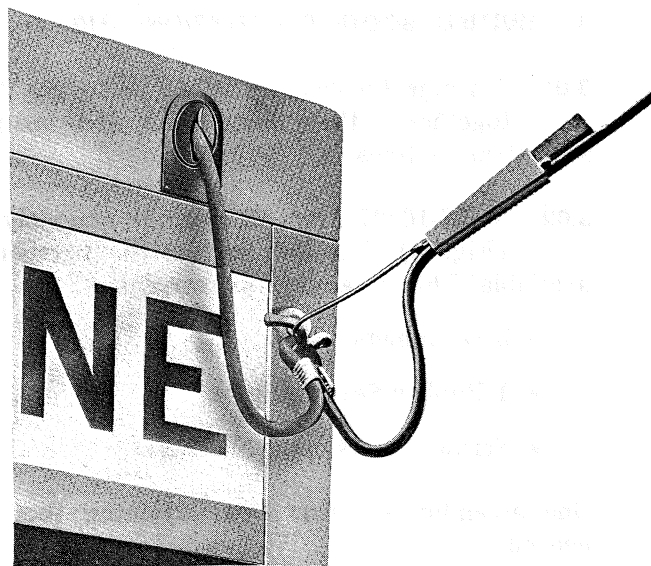

Fig. 4 – Drop Wire Hook (Right Side)

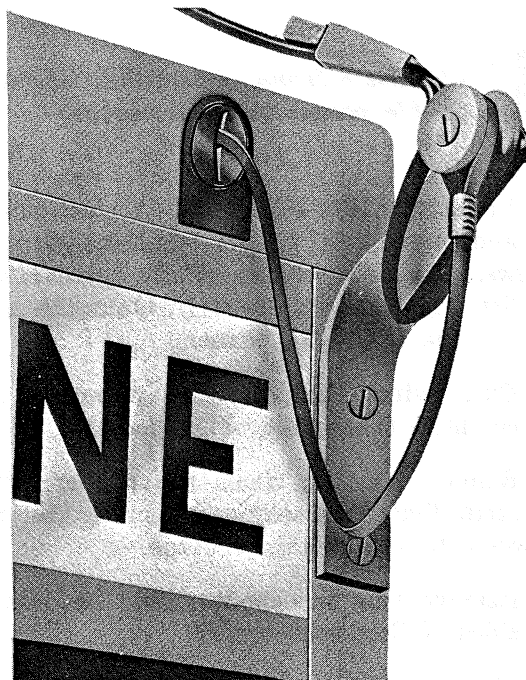
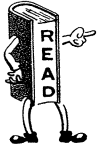

Fig. 5 – Corner Bracket as First Attachment (Right Side)

4.04 The 123A1A station protector or 42A connecting block is located under the roof on the ceiling assembly, for overhead wire entrances. For ground level entrances or underground entrances, mounting holes have been provided in the list 21 or list 121 junction box for mounting the 123A1A station protector.

Station Connections



KS-16797 booths are furnished wired as shown in Fig. 6.

4.05 The Plant Series section entitled Coin Collectors, Connections, and the section entitled Subscriber Sets, Connections, covers wire terminations.

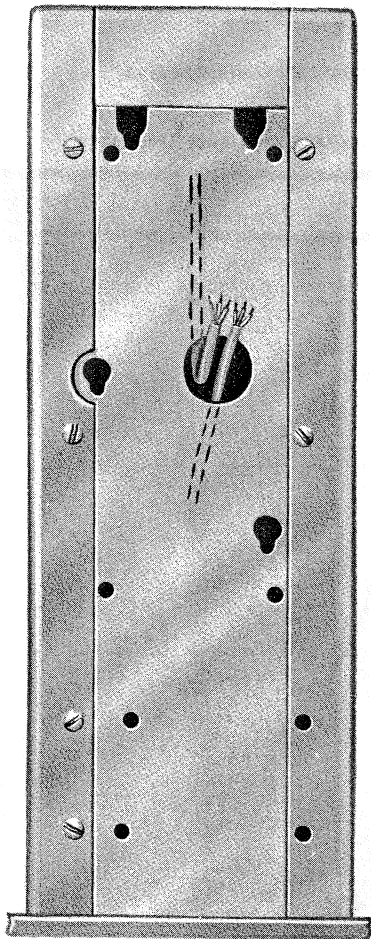

Fig. 6 — Station Connections

5. STATION PROTECTOR GROUNDING

5.01 The ground terminal of the station protector, when located in the booth, is connected to the booth with bonding wire provided. No additional grounding for the protector is required *except* when all three of the following conditions exist:

- Power system is not of the multigrounded neutral type.
- Power ground consists of a driven electrode.
- A length of less than 10 feet of the conduit associated with the booth is buried in permanently moist soil.

5.02 Refer to Plant Series entitled Protector and Signaling Grounds for detailed information.

6. ELECTRICAL WIRING

6.01 Electrical wiring and grounding of the KS-16797 booth is covered in Section 508-100-100.

6.02 A duplex receptacle for electrical wiring is located under the roof on the ceiling assembly.

6.03 Power service entrance holes are located in several locations:

- (a) Through metallic conduit located at the left rear of roof assembly (for overhead entrance).
- (b) Through entrance holes located in list 23 or list 123 solid bottom panels (for ground level entrance).
- (c) Through metallic conduit to holes provided in the left rear corner of the booth floor (for underground entrance).

6.04 *Indoor installation*, Fig. 7, power is brought into an indoor booth from the top rear of the booth with a KS-16797, List 15 cable assembly.

6.05 *Outdoor installation*, Fig. 8, power may be brought into an outdoor booth from the top

or bottom wire entrance with a KS-14611, List 20 cable and cord assembly.

6.06 Use either the KS-16797, List 14 or List 15 cable assembly to interconnect power between adjacent booths in multiple installations.

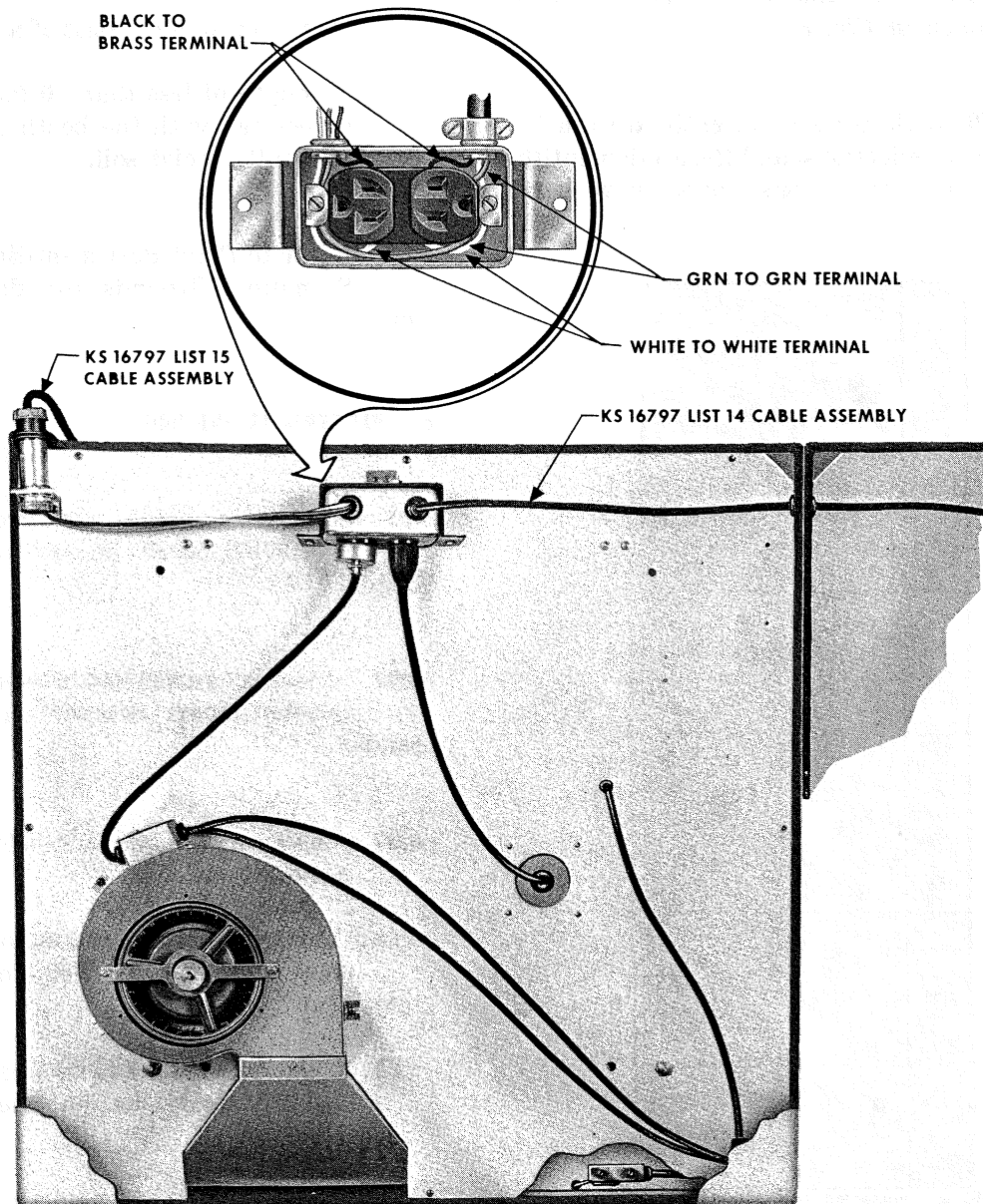
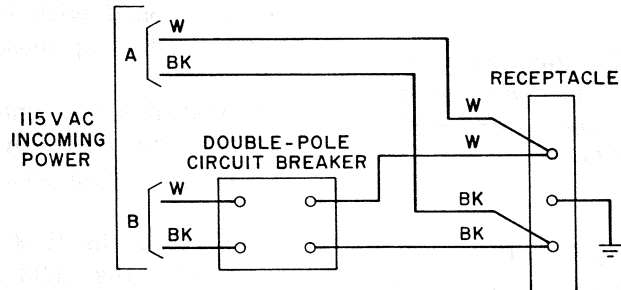

Fig. 7 – KS-16797, List 15 Cable Assembly (Power Entrance at Top of Booth)

OPTIONAL CIRCUIT DIAGRAMS
FOR LIST 21 & LIST 121 JUNCTION BOX KIT



A - NO-CIRCUIT BREAKER OPTION.
B - DOUBLE-POLE CIRCUIT BREAKER OPTION.

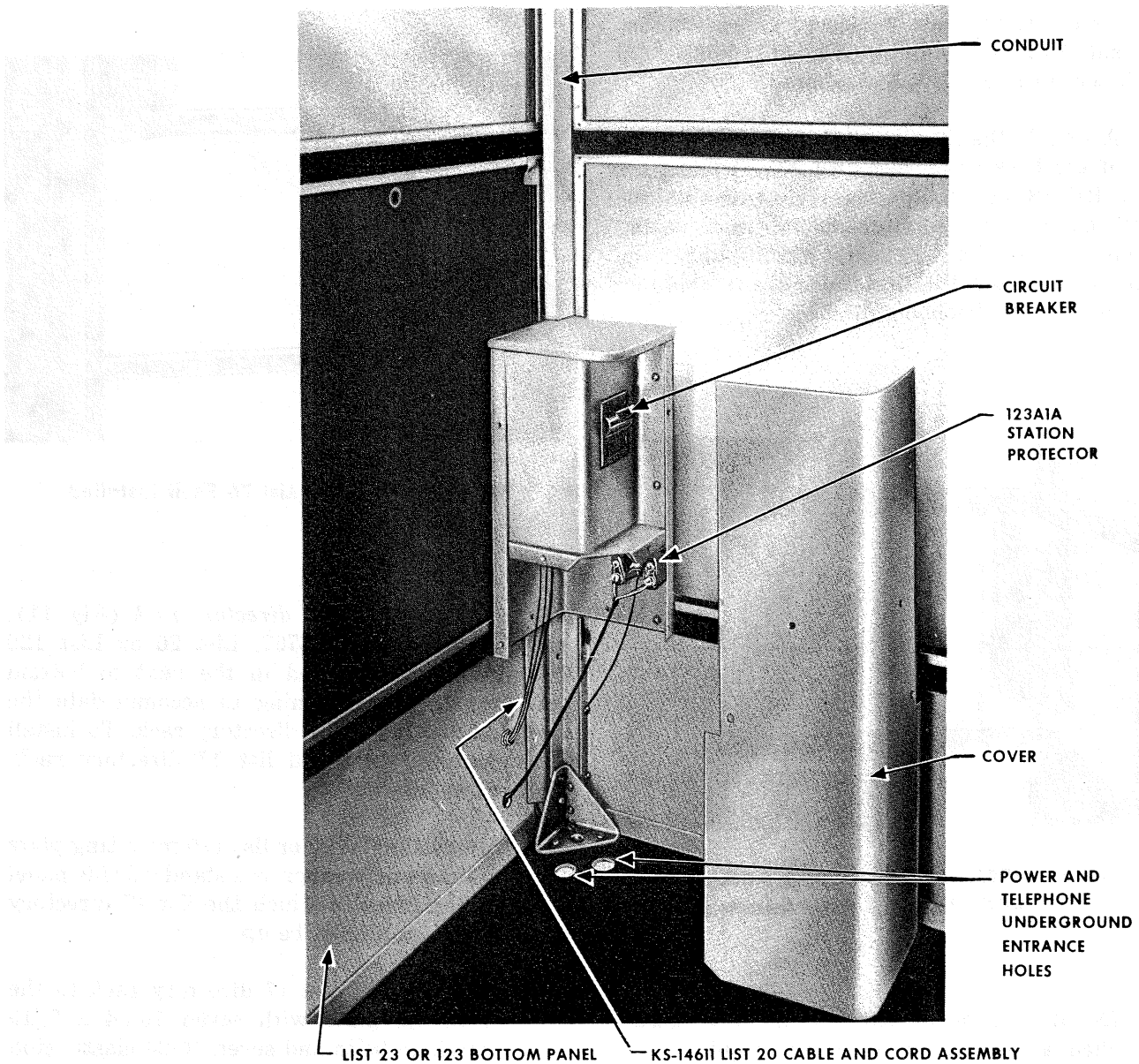
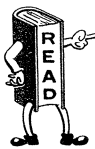

Fig. 8 - KS-14611, List 20 Cable and Cord Assembly (Power Entrance at Bottom of Booth)

7. DIRECTORY RACK AND SHELF ARRANGEMENTS



Mounting holes for directory rack and shelf arrangements are provided on the side and intermediate rails, and on the underside of the backboard.

7.01 Directory facilities in combination of a *KS-16797 List 74 directory rack and a List 75 shelf* (Fig. 9) shelf can be located in the left rear corner of the booth. Install as follows:

- (1) Assemble the list 74 directory rack to the side rail using Phillips FHM .190-32 x 1/2 inch screws and CSK-10 washers.
- (2) Assemble the list 75 shelf to the underside of the backboard with two No. 10-32 x 1/2 inch RHMS pulled up loosely. Assemble the shelf flanges to the intermediate rails using seven No. 10-32 x 1/2 inch RHMS pulled up securely. Tighten the first two screws holding the shelf to the backboard.

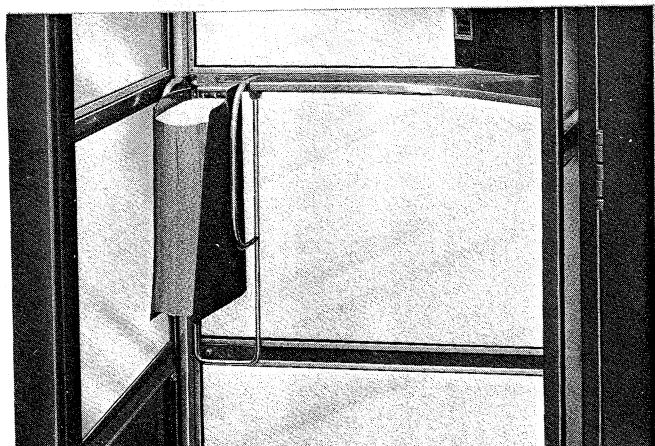

Fig. 9 – KS-16797, List 74 Directory Rack and KS-16797, List 75 Shelf Installed

7.02 *KS-16797, List 76 shelf* (Fig. 10), used when a directory rack is not required, is located along the back of the booth under the backboard. Install as follows:

- (1) Assemble the shelf to the underside of the backboard with two No. 10-32 x 1/2 inch RHMS pulled up loosely.
- (2) Assemble the shelf flanges to the intermediate rails with eight No. 10-32 x 1/2 inch RHMS pulled up securely.
- (3) Tighten the first two screws holding the shelf to the backboard.

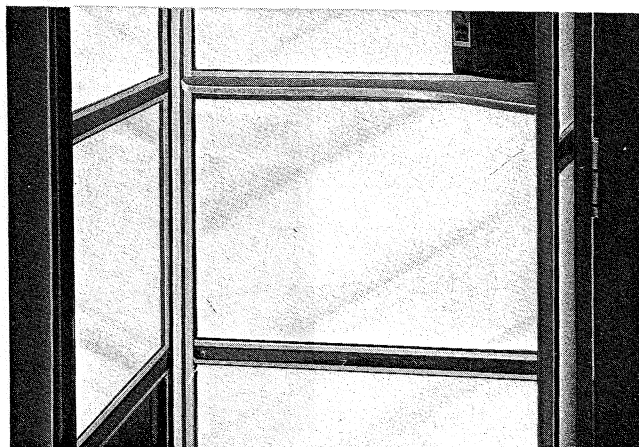

Fig. 10 – KS-16797, List 76 Shelf Installed

7.03 *KS-16797, List 17 directory rack* (Fig. 11), requires a *KS-16797, List 20 or List 120 mounting plate* installed in the next to bottom rear or side panel opening to accommodate the assembly of the list 17 directory rack. To install the mounting plate and list 17 directory rack, proceed as follows:

- (a) Install the list 20 or list 120 mounting plate in the same manner as a standard side panel except the holes to which the list 17 directory rack is secured must be up.
- (b) Assemble the list 17 directory rack to the mounting plate with seven 10-24 x 9/16 inch carriage bolts and seven 10-24 elastic stop nuts. Locate the screw heads on the inside of the booth and the nuts on the outside.

8. KS-16797, LIST 16 SEAT (FIG. 11)

8.01 A KS-16797, List 19 mounting plate must be installed in the bottom left side panel opening to accommodate the assembly of the KS-16797, List 16 seat. To install the list 16 seat and the list 19 mounting plate proceed as follows:

- (a) Install the list 19 mounting plate in the same manner as a standard side panel, except that the holes to which the list 16 seat is secured must be up.
- (b) Assemble a B-192273 clip in each of the four corners of the plate within the booth with an 8-32 x $\frac{3}{8}$ inch SEMS RHMS.
- (c) Assemble the seat to the upper portion of the panel with four $\frac{1}{4}$ inch 20 x 1- $\frac{1}{8}$ inch carriage bolts, four B-192272 spacers, the seat, two $\frac{1}{4}$ inch plain washers for the top two screws only, four $\frac{1}{4}$ inch spring washers, and four $\frac{1}{4}$ inch cap nuts in that order. Tighten the four cap nuts securely. Locate the screw heads on the outside of the booth and the nuts on the inside of the booth.

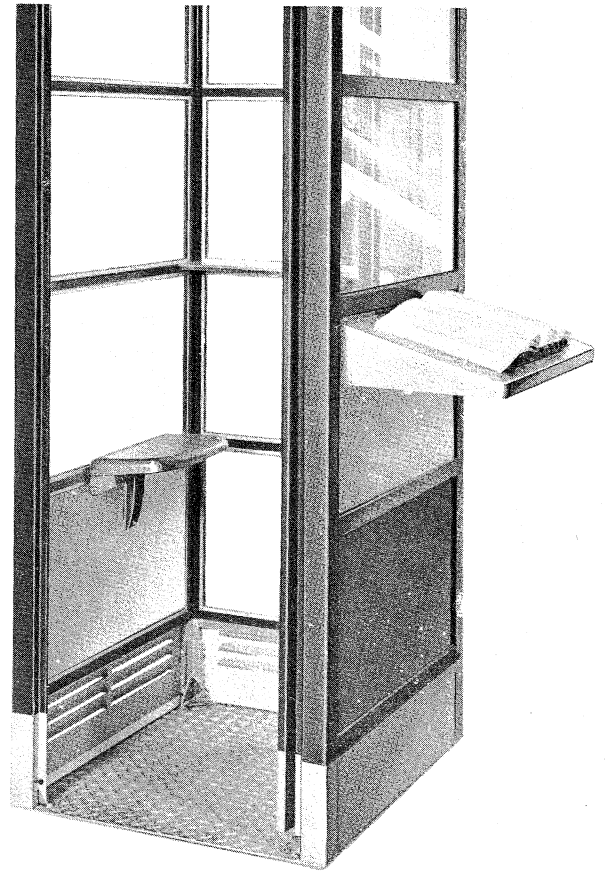

Fig. 11 – KS-16797, List 17 Shelf Installed